

RIEIC-2000SERIEIC-20

ICARUS

STEEL FRAMING MACHINE

powered by
unbak

IC-2000SERIES
IC-2000S / IC-2500SA / IC-2500SW



Unbak

Unbak

MAIN MENU

Enc. (mm) 00:03:47 Remaining (mm) 00:03:47 Elapsed Time 00:03:47 Estimated Time 00:03:47

MAC INFO

AVERAGE 25

OIL TEMP °C 22.9 / 38.4

SERVO TEMP °C 23.5 / 28.6

LIGHT

ERRORS

75

PRODUCTION SPEED

RESET

Start Stop Manual Control Settings XML

ICARUS[®]
www.unbak.com

IC-2000 SERIES LIGHT STEEL FRAMER



IC-2000 SERIES LIGHT STEEL FRAMER

With IC-2000 Series machines, you can process maximum **1.6mm / 16GA** S350 high-strength metal sheet, and you can work with one or multiple web width sizes depending on the machine model you choose.

The rollform unit consists of 12 rollform stations and is powered by an 29Nm motor.

The hydraulic unit works with a 11 KW motor. Hydraulic oil tank is 150lt.

Machine main control unit (PLC) accepts Vertex BD, Framebuilder MRD and Structsoft datas. Machine is controlled with 21" Touch Screen.

All produced profiles are marked with Inkjet.

Profile Selections:

Web Width Between 60 to 150mm / 2,5" to 6" (3+ Different Sizes)
Single Flange Height 41,3 (One Size)

Machine Dimensions: 4500 x 900 x 1650 mm / 14,7' x 2,9' x 5,2'

PUNCH SETS

Pre Punches: Web Notch, Lip Notch, Dimple, Service Hole, Truss End, Optional Punch

Post Punches: SABS Equipments, Swage, Cut Off.

MACHINE MODELS

IC-2000S: One Web Width Size Profile production.

IC-2500SA: Multiple Web Width Size Profiles production. Semi Auto Adjustment Manual Multiple Web Width Sizes

IC-2500SW: Multiple Web Width Size Profiles production. Servo Width Adjustment (Multiple Web Width Size by Auto Adjustment)

SUPPORTED UNBAK TECHS

3 STAGE CUT

LGSFLEX
UPGRADABLE LGS-MACHINE SYSTEM

SABS STEEL ANTIBLOCKING SYSTEM

BD Vertex BD

StrucSoft
SOLUTIONS

FRAMEBUILDER-MRD
PROFILER PROFILE SOFTWARE

SABS (STEEL ANTIBLOCKING SYSTEM): SABS system, developed by UNBAK Machinery, prevents sheet metal jamming inside the machine during profile production.
LGSFLEX: Allows the machine to remain up to date even after years of use — enabling future updates of web width and punching config. without replacing the system.
3 STAGE CUT: Automatically detects whether the profile has a rebate or not and applies the correct cut, ensuring perfectly straight edges and precise panel assembly.

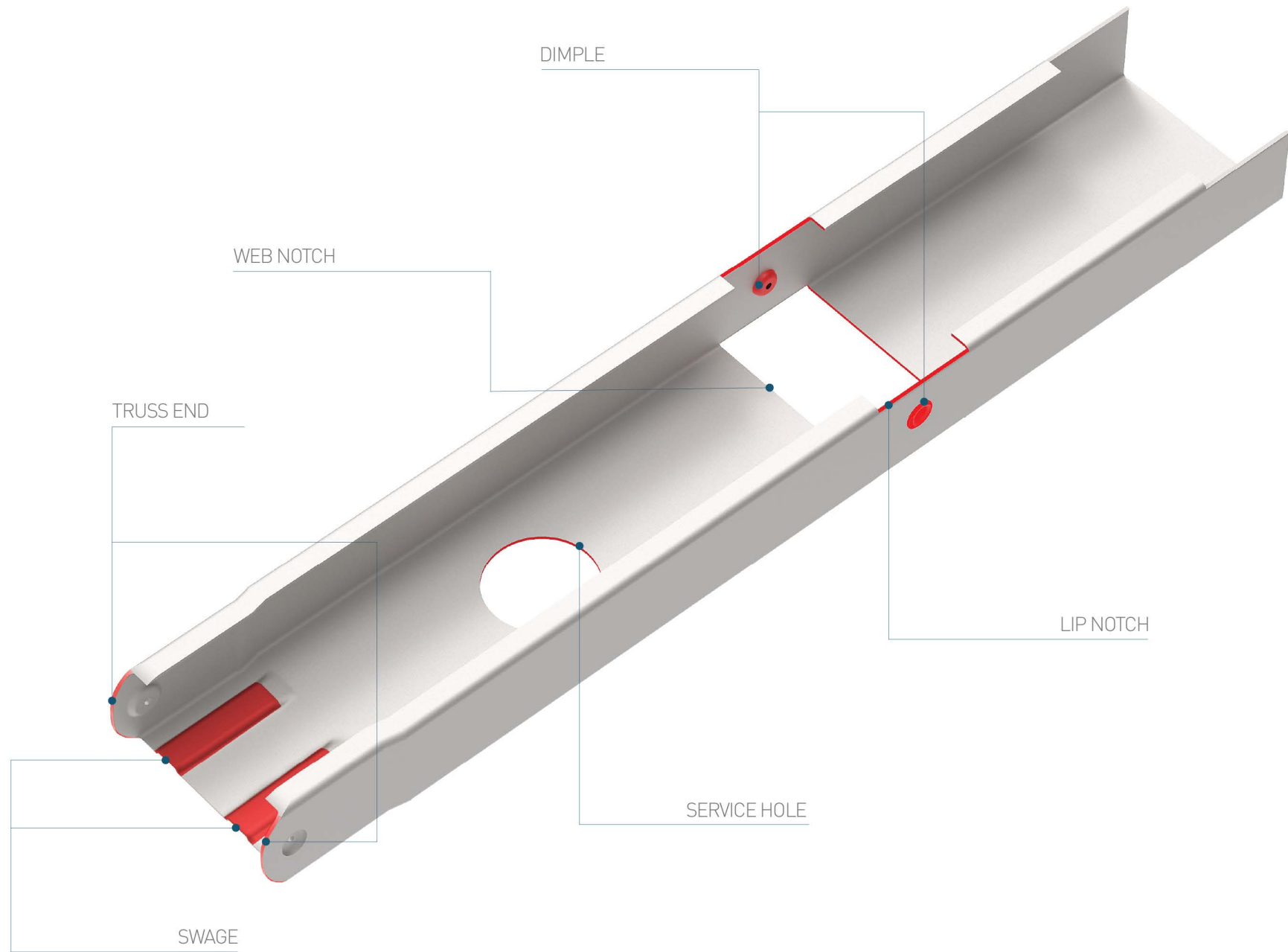

PUNCH DETAILS

IC-2000SERIES PUNCHS



Dimple

The dimple holes are punched in the center of the flange. They accurately locate the joining components and are recessed so that the head of the screw sits flush and allows the drywall to fit flat on the framing.



Truss End

Notches chamfer on the Flanges on both sides of the section to allow a better fit and connection for angular joints. Mainly used on bracing components and trusses



Service Hole

The service hole is available in one of several sizes, which can be selected when placing an order. A service hole can be punched into the studs and plates wherever cabling or plumbing is required

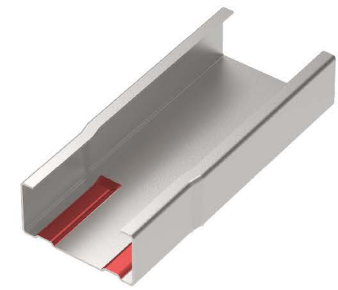

Swage

The swage crimps the section allowing it to fit inside a plate while maintaining the same overall external sizes for both plates and studs. This allows the cladding or drywall to sit completely flat against the framing and gives improved end bearing between the stud and plate intersections.

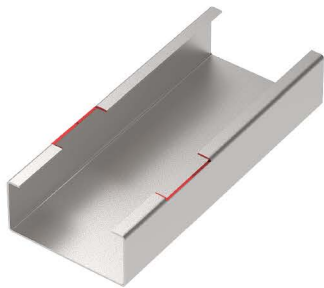

Lip Notch

The lips are notched out to allow the stud to pass through, it can be used by itself or in conjunction with the web notch.

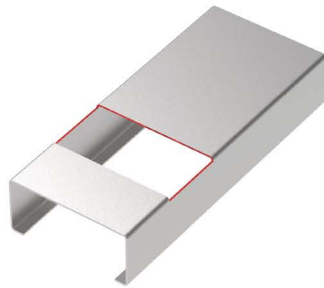

Web Notch

The web is notched out to allow one stud to pass through another. It can be used by itself or in conjunction with the lip notch.

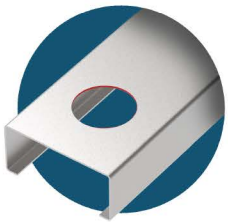
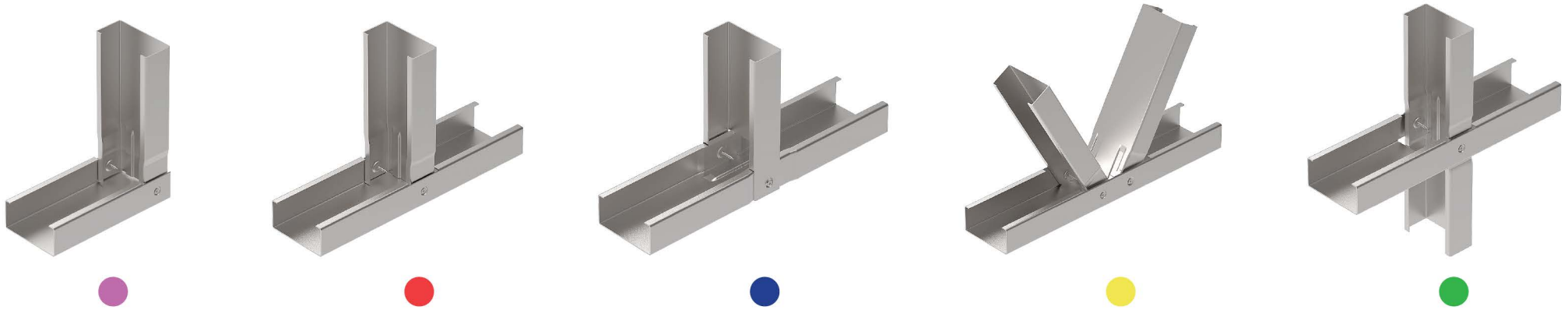

Service Hole is the holes on the profiles that you see in the example wall panel on the side. Walls are created smoothly and without deformation by passing installation elements such as cables and pipes through the installation holes that are automatically applied to the profile during production.

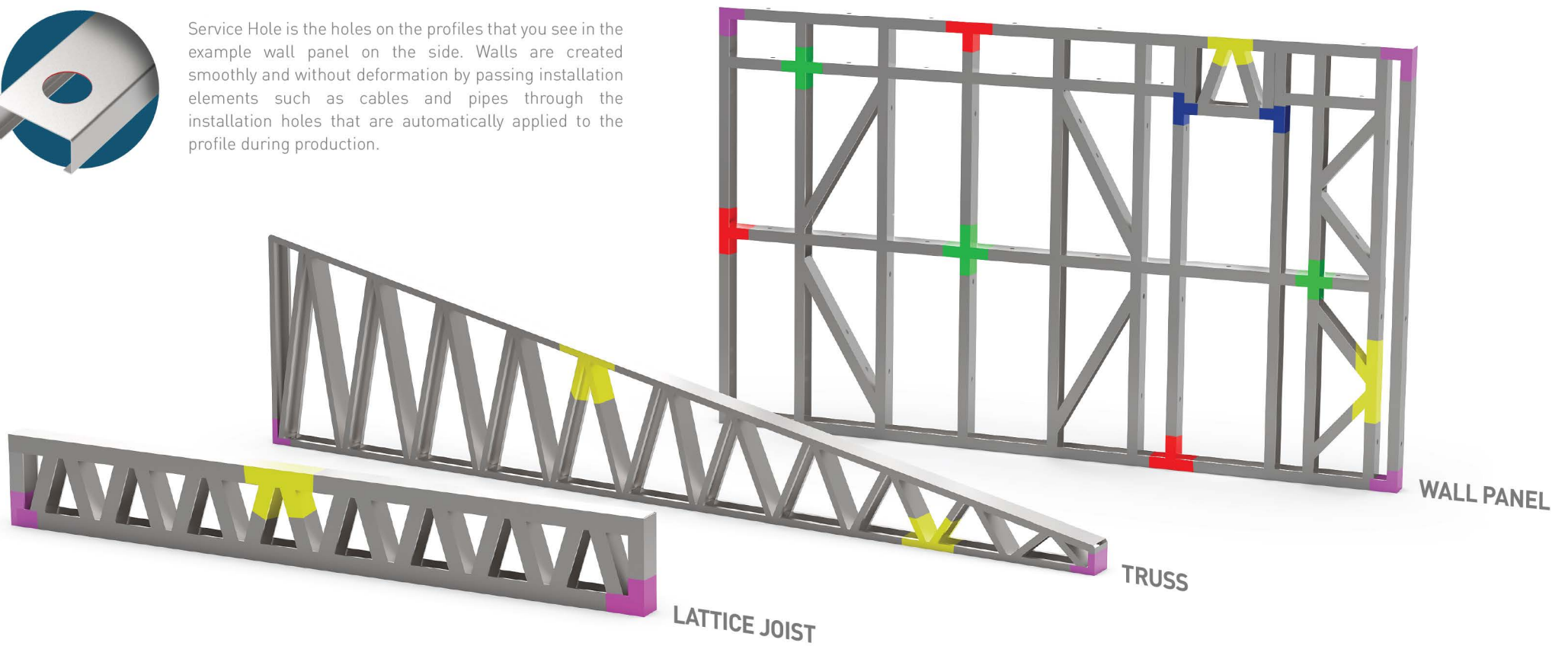

CONNECTION DETAILS

LSF CONNECTIONS

Area of Use

Wall Panel, Truss, Lattice Joist

Used Punches

Swage, Dimple, Lip Notch

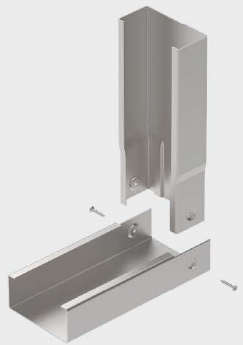

Area of Use

Wall Panel, Truss, Lattice Joist

Used Punches

Swage, Dimple, Lip Notch

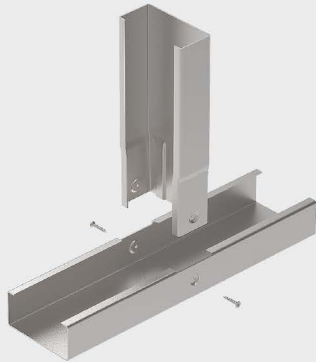

Area of Use

Wall Panel, Truss

Used Punches

Swage, Dimple, Lip Notch, Web Notch

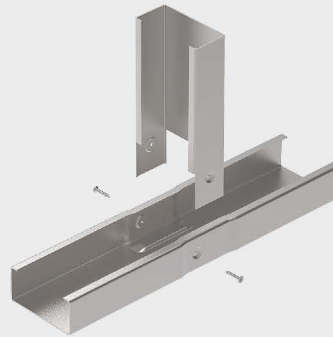

Area of Use

Wall Panel

Used Punches

Swage, Dimple, Lip Notch, Web Notch

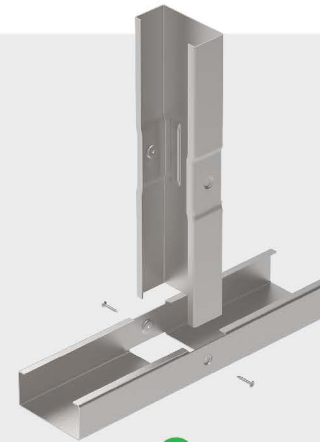

Area of Use

Wall Panel, Truss, Lattice Joist

Used Punches

Lip Notch, Swage, Dimple, Truss End

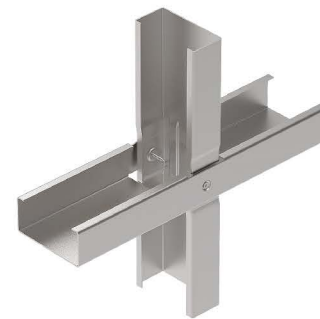
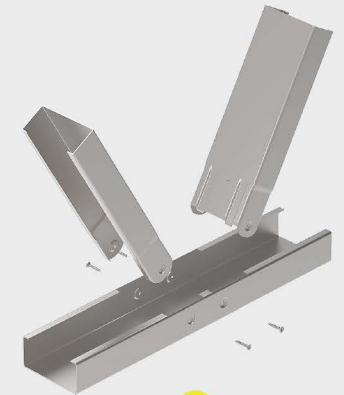

MODEL	IC-1000B	IC-1000SA	IC-2000S	IC-2500SA	IC-2500SW	IC-3000SERIES	IC-5000SERIES	IC-7000SERIES
	Lattice Joist	Lattice Joist	Lattice Joist	Lattice Joist	Lattice Joist	Lattice Joist +Floor Joist	Lattice Joist +Floor Joist	Floor Joist + Coloum
DESIGN SOFTWARE	FrameBuilder or Vertex BD or Structsoft	FrameBuilder or Vertex BD or Structsoft	FrameBuilder or Vertex BD or Structsoft	FrameBuilder or Vertex BD or Structsoft	FrameBuilder or Vertex BD or Structsoft	FrameBuilder or Vertex BD or Structsoft	FrameBuilder or Vertex BD or Structsoft	FrameBuilder or Vertex BD or Structsoft
PROFILE QUANTITY	1 X C, 1 X U One Size	3 X C, 3 X U Multiple Sizes Manual Change	1 X C, 1 X U One Size	3 X C, 3 X U Multiple Sizes Manual Change	3 X C, 3 X U Multiple Sizes Servo Oto. Change	"S" Coded Mac. 1 X C, 1 X U "SA" Coded Mac. 5 X C, 5 X U +Optional C Section	"S" Coded Mac. 1 X C, 1 X U "SA" Coded Mac. 5 X C, 5 X U +Optional C Section	"S" Coded Mac. 1 X C, 1 X U "SA" Coded Mac. 3 X C, 3 X U +Optional C Section +Sigma Section
WEB / PROFILE FLANGE	Selected Web X 41mm / 1.6"	Selected Web X 41mm / 1.6"	Selected Web X 41mm / 1.6"	Selected Web X 41mm / 1.6"	Selected Web X 41mm / 1.6"	WEB: 60/2,5"- 90/3,5" - 150/6" - 200/8" - 250/10" FLANGE: 50/2" or CUSTOM SIZE	WEB: 60/2,5"- 90/3,5" - 150/6" - 200/8" - 250/10" FLANGE: 50/2" - 60/2,4" (70/2,8" Optional)	400 x 65mm / 16" x 2 1/2" max SIGMA OPTION AVAILABLE
MAX STEEL THICKNESS	1,20 mm / 18ga	1,20 mm / 18ga	1,60 mm / 16ga *OPTIONAL 2mm / 14ga	1,60 mm / 16ga *OPTIONAL 2mm / 14ga	1,60 mm / 16ga *OPTIONAL 2mm / 14ga	2,50 mm / 12ga	2,50 mm / 12ga	3,00 mm - 4,00 mm / 11ga - 9ga
STEEL QUALITY	S250	S250	S350	S350	S350	S350 - (Optional S500)	S350 - S500	S350 - S500
STATION QUANTITY	10	10	12	12	12	17 ** *Inclined Rollers Are Optional	22 ** 16 + 6 Inclined Rollers Are Optional	30 ** 26 + 4 for Sigma Sections
PRODUCTION SPEED * (VARIABLE DEPENDING ON DESIGN)	Wall - 800 m/hr Lattice Joist - 200 m/hr	Wall - 800 m/hr Lattice Joist - 200 m/hr	Wall - 800 m/hr Lattice Joist - 200 m/hr	Wall - 800 m/hr Lattice Joist - 200 m/hr	Wall - 700 m/hr Lattice Joist - 200 m/hr	Wall - 700 m/hr Lattice Joist - 200 m/hr Floor Joist - 300 m/hr	Wall - 700 m/hr Lattice Joist - 200 m/hr Floor Joist - 300 m/hr	Wall - 600 m/hr FLoor Joist - 300 m/hr
MAIN MOTOR POWER	12.8 Nm	12.8 Nm	29 Nm	29 Nm	29 Nm	50 Nm	50 Nm	129 Nm
HYDROLIC MOTOR POWER	5 KW	5 KW	11 KW	11 KW	11 KW	11 KW	11 KW	15 KW
LENGHT	3500 / 11,5ft	3500 / 11,5ft	5000 / 16,4ft	5000 / 16,4ft	5000 / 16,4ft	8500 / 27,8ft	9000 / 29,5ft	17000 / 55,7ft
WIDTH	900 / 2,9ft	900 / 2,9ft	900 / 2,9ft	900 / 2,9ft	1000 / 3,3ft	1250 / 4ft	1600 / 5,2ft	2500 / 8,2ft
HEIGHT	1450 / 4,7ft	1450 / 4,7ft	1600 / 5,2ft	1600 / 5,2ft	1700 / 5,5ft	2000 / 6,5ft	2250 / 7,4ft	1900 / 6,2ft
WEIGHT (KG)	3500	3500	5500	5500	6000	9000	10000	10000+
OPTION LIST	-	-	Optional +1 Punch 2.00mm Thickness is Opt.	Optional +1 Punch 2.00mm Thickness is Opt.	Optional +1 Punch 2.00mm Thickness is Opt.	Servo Full Automatic Control	Servo Full Automatic Control	Automatic Sheet Metal Adj. Automatic Section Change Automatic Sigma On/Off
SABS STEEL ANTI-BLOCKING S.	-	-	Yes	Yes	No	Not Needed	Not Needed	Not Needed
MACHINE CODES DESCRIPTION	"S" Code Machine Extension stands for: ONE WEB WIDTH SIZE - "SA" Code Machine Extension stands for: SEMI-AUTOMATIC ADJUSTMENT / MANUAL MULTIPLE BASE SIZE "SW" Code Machine Extension stands for: SERVO BASE SIZE CHANGE - "C" Code Machine Extension stands for: DESIGNED FOR SPECIAL PROJECTS.							
PUNCHES	(7 Punch) Dimple, Web Notch, Servici Hole, Truss End, Swage, Lip Notch,Cut to Lenght (Extra Mold can be ordered for Every Series)					(9 Punch) Dimple, Web Notch, Service Hole, Truss End, Swaga, Lip Notch, Cut to Lenght Mid Tab Connection, Swaged Service Hole, Flange Hole (Floor Joist Punches) (Extra Punches can be Ordered)		

** Depending on steel quality, web and flange details it can be change.

* Production speed may vary depending on design.

* Red Value represents imperial measurement.



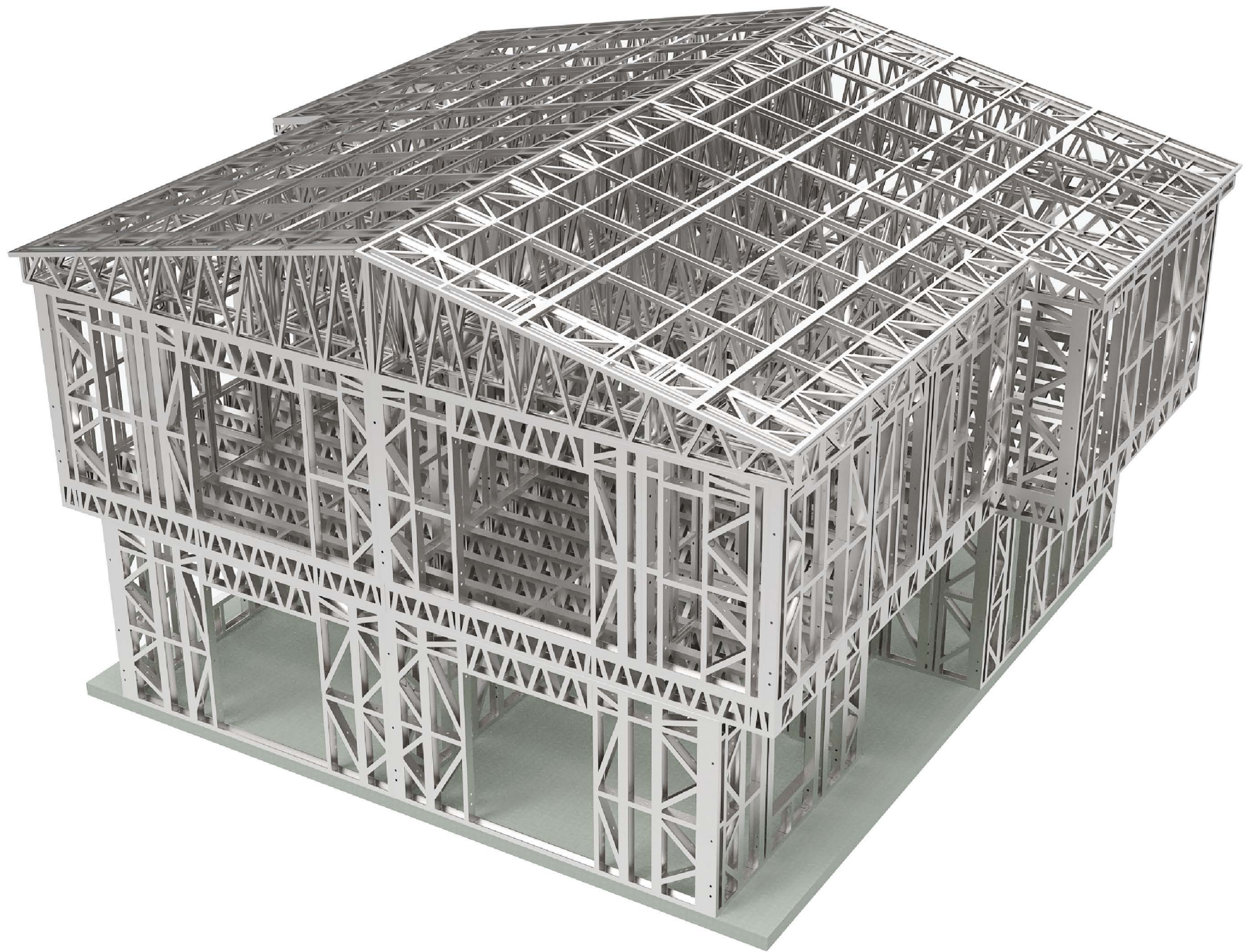

CONNECTION DETAILS

LSF CONNECTIONS



Wall Frames

At the heart of any building lies its skeletal structure, and for many modern structures, this skeleton is built from light gauge steel. Wall frames, also known as steel studs or framing items, are the vertical and horizontal members that form the primary support for the exterior and interior cladding, insulation, and utilities. Made from sheet steel that has been formed into specific shapes through cold-forming processes, these frames offer a modern alternative to traditional timber framing.

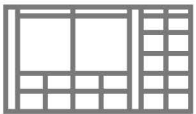

Trusses

Trusses are the primary structural components that span across the roof, providing support for the roofing material. Light gauge steel trusses can be prefabricated off-site, ensuring precision and rapid installation.



Lattice Joist

Thanks to these joists, larger openings can be passed with thinner steel thicknesses. The joist heights required to pass the large openings can be produced as desired. It is possible to produce more strength joists with lighter profile thicknesses.



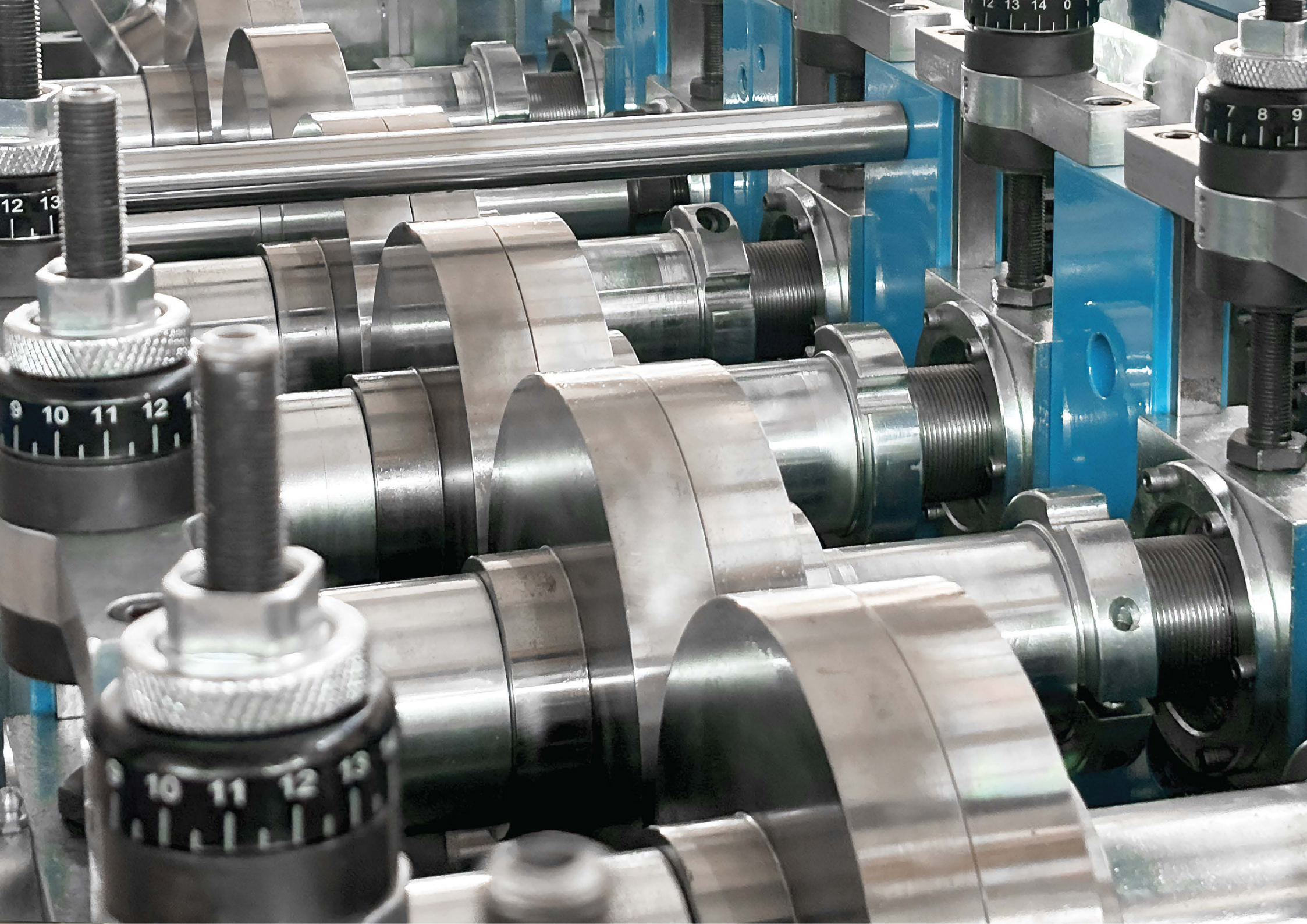

UNBAK LIGHTS STEEL FRAME MACHINERY

WORLDWIDE MACHINE NETWORK AND SERVICE SUPPORT

Being the most valuable and reliable business partner of our customers is our main reason for existence since 1991 (by the first generation). Therefore, our client focuses on success; our business that creates the most value for our customers with our expertise, innovative solutions and sustainable management approach.

We are working to become a solution partner. With our strategy of winning our customers for life, every long term relationship with each customer on 5 continents we establish, we mutually invest in the future. Today, our customers in many sectors we work with in the global arena ensure sustainable progress, Rely on UNBAK machines to improve and grow. Because we enhanced the professional creativity of our customers with our high performance machines, improves their potential, their way of living and working and continue to developing. UNBAK Machinery about History

SERVICE NETWORK

The continuity of a safe and reliable service at ÜnbaK and the continuity of our customers' business without interruption is one of our basic principles. For this purpose, our professional field team that we have created in a way to serve worldwide and the established service with state-of-the-art equipment. With our workshop, we are always with our customers and at your service. With special software and hardware created as a result of our Research and Development Program created by our engineers.

With our technological infrastructure at the highest level we have created, we can make fault determinations with zero errors and solve the damages quickly. It detects possible damages precisely by controlling on site or by connecting remotely; we plan repair processes quickly. It stores all the transactions in electronic environment; we save time and maximize machine uptime.

UNINTERRUPTED PRODUCTION
WORLDWIDE QUALITY
INNOVATIVE DESIGN
GLOBAL SERVICE & SUPPORT
COMPETITIVE PRICE



